

Name: JR Mitch Date: 02/02/2013 Event: Super Cup Round 2  
 City: Ocala State: Florida Track: NewRed Hobbies

Track Conditions:  Indoor  Tight  Smooth  Hard Packed  Blue Groove  Wet  Grass  Low Bite  High Bite  
 Outdoor  Open  Rough  Loose/Loamy  Dry  Dusty  Astro Turf  Med Bite  Other \_\_\_\_\_

### Front Suspension

Toe: +/- 0 degrees  
 Ride Height: 28mm  
 Camber: -1 degree  
 Caster:  0°  3°  5°  10°  
 Kick Angle:  20°  25°  30°  
 Sway Bar: 1.2mm (Yellow)  
 Shock Type:  Bladder  Emulsion Oil: 32.5 wt.  
 Piston: 2 x 1.5mm  
 Spring: Blue (TLR5183)  
 Shock Limiters: 3mm  
 Shock Location: 2 - Outside  
 Bump Steer: 1mm  
 Camber Link: 1 (Inside)

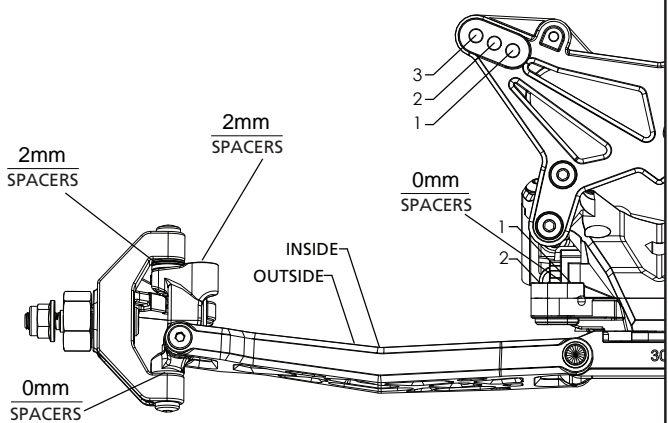

Notes: Aluminum Front Pivot, 30 deg (TLR1105)

### Rear Suspension

Chassis Configuration:  Rear Motor  Mid Motor  
 Differential:  Ball Diff  Gear Diff Gear Diff Fluid: \_\_\_\_\_  
 Toe: 3.5 LRC  
 Anti-Squat: 2 degree  
 Roll Center:  Low Roll Center (LRC)  High Roll Center (HRC)  
 Ride Height: 28mm  
 Camber: -1 degree  
 Rear Hub Spacing: 2mm Front, 2mm Rear (Middle)  
 Hex Width: Standard  
 Sway Bar: 1.0mm (White)  
 Shock Type:  Bladder  Emulsion Oil: 30 wt.  
 Piston: 2 x 1.6mm  
 Spring: Buggy Yellow (TLR5167)  
 Shock Limiters: None - One turn unscrewed  
 Camber Link: 1 - E  
 Shock Locations: 2 - Inside  
 Battery Position: Middle

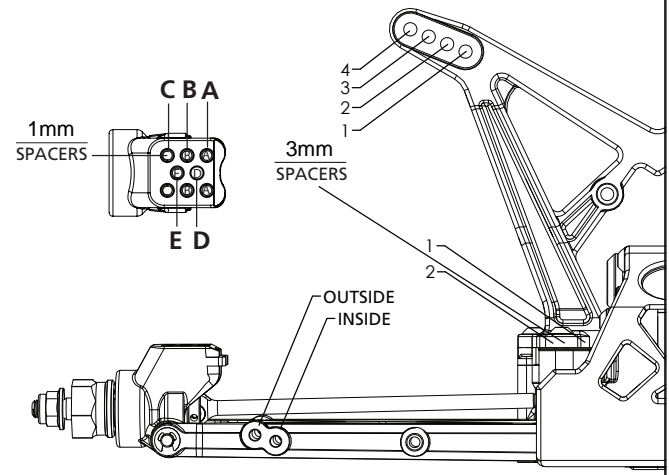

### Electronics

Radio: DX3R Pro Timing Advance: None  
 Servo: SPM S6040 Throttle/Brake Expo: 0/0  
 ESC: Orion R10 Pro Servo Expo: None  
 Initial Brake: \_\_\_\_\_ Throttle/Brake EPA: 95/85  
 Drag Brake: \_\_\_\_\_ Motor: Trinity D3.5 6.5T  
 Throttle Profile: \_\_\_\_\_ Pinion: 16 Spur: 84  
 Battery: Trinity REV2021

Weight Placement (Mark with "X")

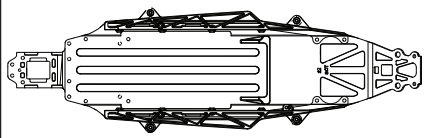

Weight of each piece \_\_\_\_\_ oz./g

Tires	Compound	Insert	Additive
Front: <u>JC Pressure Points</u>	<u>Blue</u>	<u>Stock</u>	<u>None</u>
Rear: <u>JC Pressure Points</u>	<u>Blue</u>	<u>Stock</u>	<u>None</u>

Notes: Aluminum Rear Camber Block (TLR2060)