

Name: Recommended Carpet Setup (requires optional parts) Date: \_\_\_\_\_ Event: \_\_\_\_\_  
 City: \_\_\_\_\_ State: \_\_\_\_\_ Track: \_\_\_\_\_



**Track Conditions**

Dirt  Carpet  Tight  Smooth  Hard Packed  Dry  
 Clay  Astro Turf  Open  Rough  Loamy  Wet

Grip Level:  Low  Medium  High  
 Tread Level:  Pin  Ghost Pin  Slicks

**Front Suspension**

Toe: +1 Deg. Camber: -2 Deg.  
 Ride Height: 14mm Caster Block:  6°  9°  12°  
 Shaft Dia:  3.0  3.5 Piston: 2 x 1.6mm Oil: 60wt  
 Limiters: Internal: 2mm External: 1mm Stroke: 22mm  
 Shock Eyelet:  Std.  +2 Shock Location: 2 - Inside  
 Spring: LF Gold (TLR233054) Sway Bar: 2.0mm  
 Steering Brace:  Posts  Posts to Gearbox  
 Rack Location:  1  2 Rack:  Composite  Aluminum  
 Spindle Steering Arm:  1  Other \_\_\_\_\_  
 Spindle Ball Stud:  Standard  Low Spacers: \_\_\_\_\_  
 Draglink Ball Stud:  Standard  Low Spacers: 2mm  
 Bell Crank Arm Location:  1  2  Other \_\_\_\_\_  
 Hex Width (mm):  4.0  4.5  5.0  5.5  
 Camber Link, Inner:  1  2 Outer Spacers: \_\_\_\_\_  
 Mud Guard:  Soft  Stiffezel  
 Front Wheels:  22X-4 Std  Other Schumacher Premounts  
 Front Wing:  None  TLR Scoop  Other \_\_\_\_\_  
 Diff Gears:  Steel  Composite Planet Gears:  2  4  
 Diff Oil: 20,000cs Ring/Pinion:  Steel  Composite  
 Driveshaft:  X74mm CVA  74mm LCD  \_\_\_\_\_

**Stiffezel Parts**

Front Arm  Rear Arm  
 \_\_\_\_\_

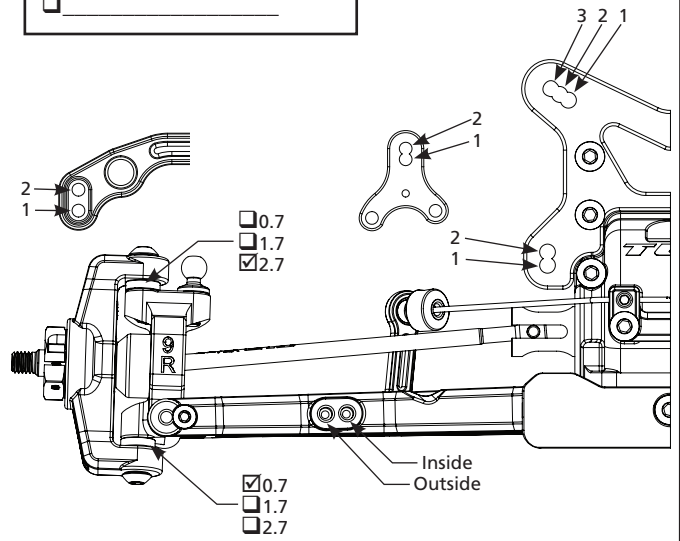

**Center Drive**

Motor Mount Location:  Forward  Rearward  
 Drive Type:  Slipper  Center Diff  
 Slipper Pads:  Torque (yel)  Drive (org)  
 Diff Gear:  Steel  Composite Planet Gears:  2  4  
 Diff Oil: \_\_\_\_\_ Diff Cover:  Composite  Aluminum

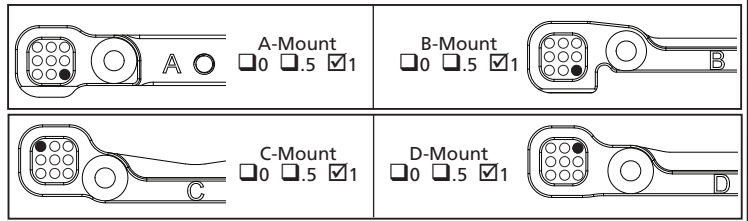

**Rear Suspension**

Gear Box Shim:  None  2mm  \_\_\_\_\_  
 Axle Height:  0  +1  +2  +3  +4  
 Ride Height: 14mm Camber: -2 Deg.  
 Hub Spacing: 2mm Fr 1mm Rr \_\_\_\_\_  
 Hex Width (mm):  4.0  4.5  5.0  5.5  6.0  
 Shaft Dia:  3.0  3.5 Piston: 2 x 1.8mm Oil: 50wt  
 Spring: LF Red (TLR233059) Sway Bar: 2.0mm  
 Limiters: Internal: - External: 4mm Stroke: 30.0mm  
 Shock Eyelet:  Std.  +2 Shock Location: 2 - Inside  
 Camber Link, Inner:  1  2 Outer:  A  B  C  
 Front Battery Spacer:  None  1  2  3  
 Diff Gears:  Steel  Composite Planet Gears:  2  4  
 Diff Oil: 15,000cs Ring/Pinion:  Steel  Composite  
 Driveshaft:  X67mm  X68mm  Other \_\_\_\_\_  
 CV Pin Position:  1  2  3  4  
 Wing/Wickerbill: 1 Line  
 Wing Angle:  0°  2°  4° Wing Height: \_\_\_\_\_

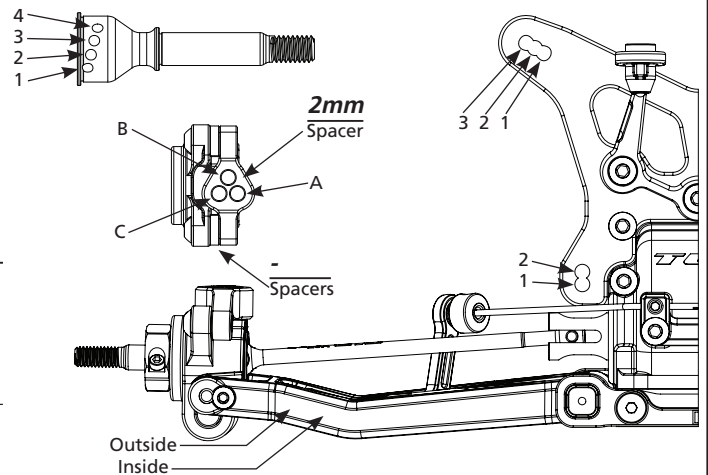

**Tires**

Brand:	<u>Front Schumacher</u>	<u>Rear Schumacher</u>
Tread:	<u>Cactus Fusion</u>	<u>Cactus</u>
Compound:	<u>Yellow</u>	<u>Yellow</u>
Insert:	<u>Premount</u>	<u>Premount</u>
Sauce:	<u>-</u>	<u>-</u>

**Chassis**

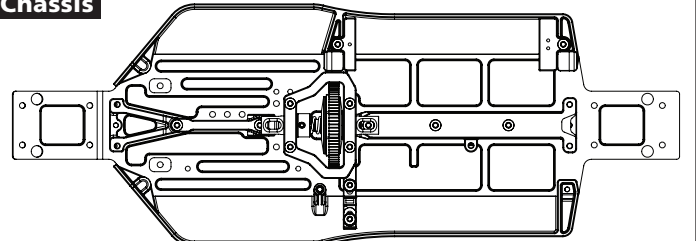

Electronics Plate  
 Carbon  
 \_\_\_\_\_

Total Weight: \_\_\_\_\_  
 FR: \_\_\_\_\_ % RR: \_\_\_\_\_ %

**Notes**

**Electronics**

Radio: \_\_\_\_\_ Steering Expo: \_\_\_\_\_  
 Servo: \_\_\_\_\_ Throttle/Brake EPA: \_\_\_\_\_  
 ESC: \_\_\_\_\_ Motor: \_\_\_\_\_  
 Initial Brake: \_\_\_\_\_ Spur/Pinion: \_\_\_\_\_  
 Drag Brake: \_\_\_\_\_ Battery: \_\_\_\_\_  
 Throttle Profile: \_\_\_\_\_ Battery Weight: \_\_\_\_\_  
 Timing Advance: \_\_\_\_\_